



**AVERY
DENNISON**

Fastener
Solutions

7.5" Standard Cable Ties Marketing Specifications

For the following part numbers:

08387-0

08388-0

08402-0

08436-0

08437-0

August 1, 2018

EVERY DENNISON MARKETING SPECIFICATION

HISTORY

THE SUBJECT MATTER DISCLOSED HEREIN EMBODIES PROPRIETARY INFORMATION WHICH IS THE CONFIDENTIAL PROPERTY OF THE EVERY DENNISON CO. NONE OF WHICH SHALL BE COPIED, REPRODUCED, DISCLOSED TO OTHERS, PUBLISHED OR USED IN WHOLE OR IN PART, FOR ANY PURPOSE OTHER THAN THAT FOR WHICH IT IS BEING MADE AVAILABLE WITHOUT THE EXPRESS ADVANCE WRITTEN PERMISSION OF A DULY AUTHORIZED AGENT OF THE COMPANY. THIS DOCUMENT IS THE PROPERTY OF THE EVERY DENNISON CO. AND IS TO BE RETURNED TO THE COMPANY ON DEMAND.

| REV. | DATE | DESCRIPTION |
|------|----------|---|
| K | 01.24.14 | UPDATED TO THE NEW FORMAT; UPDATED DIM 5 FOR EASE OF INSPECTION |
| L | 09.25.14 | ADDED MIN INSTALL TEMP; UL LOGO AND 5000 PER CASE CHG LOOP TENSILE TO NEWTONS |

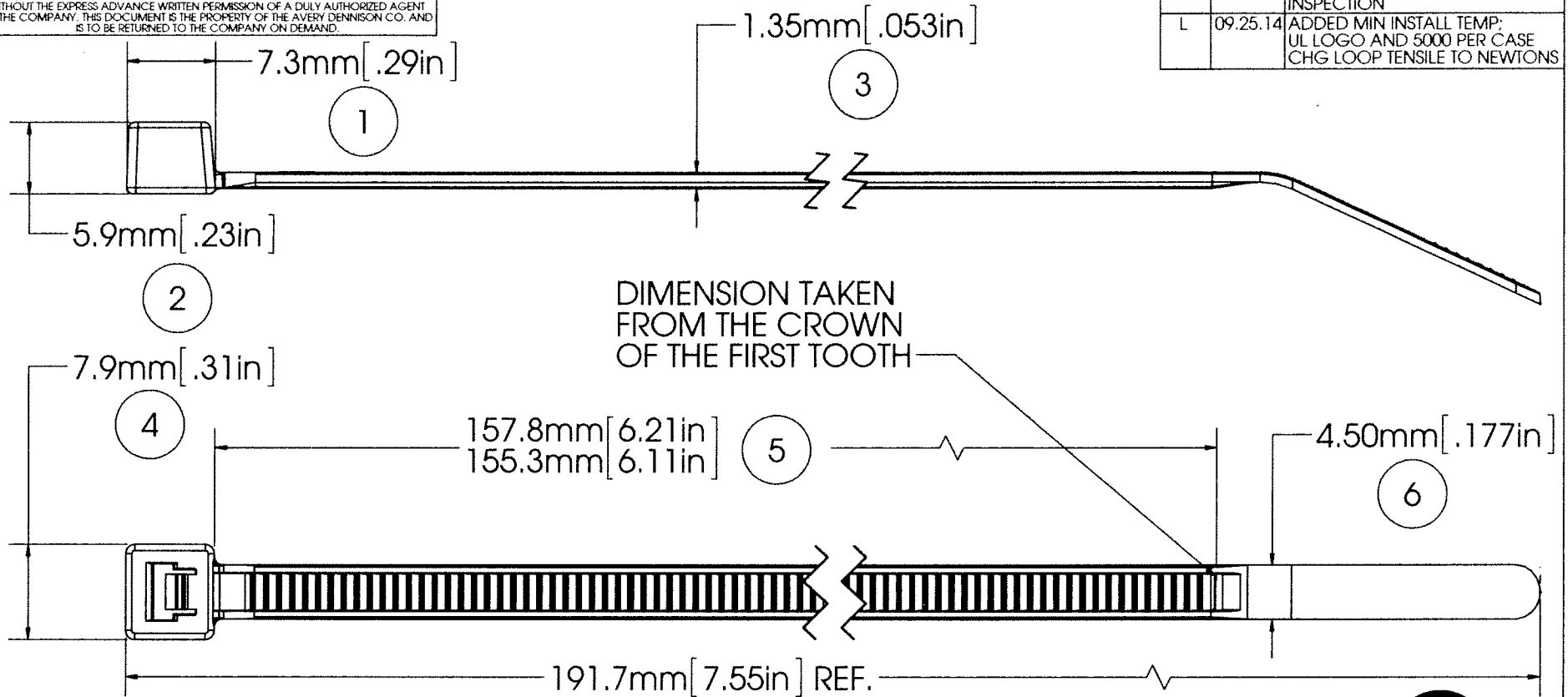

NOTE: THESE CABLE TIES ARE PLENUM RATED AND HAVE A FLAMMABILITY RATING OF V-2



| | |
|-------------------------|---|
| LOOP TENSILE STRENGTH: | 50 LBF / 220N MIN. PER AS-23190 |
| OPERATING TEMP: | -40°F (-40°C) TO 185°F (85°C) |
| MIN. INSTALLATION TEMP: | 32°F (0°C) |
| WEIGHT: | 0.041 OZ./1.20 GRAMS |
| BUNDLE DIAMETER: | 1.59mm - 44.5mm |
| TOOL: | 12001 - HAND INSTALLATION TOOL 12500 - PNUM. INSTALLATION TOOL |
| TOOL TENSION SETTING: | 6 - 8 |
| PACKAGING: | 1000/BAG 5000/CASE; (100 PACKS AVAILABLE) |

| | |
|------------|---------------------------------------|
| APPROVALS: | ENG. APPR. <i>[Signature]</i> 9/25/14 |
| | Q.A. APPR. <i>[Signature]</i> 9/25/14 |

| | | |
|---------------------------|--------------|-----------|
| SPECIFIED TOLERANCES ARE: | | MATERIAL |
| .XX ± .03 IN. | .X ± .7 MM | NYLON 6/6 |
| .XXX ± .01 IN. | .XX ± .25 MM | COLOR |
| | | NATURAL |

| | | |
|-----------------------|---|---------------------|
| EVERY DENNISON | <small>FASTENER DIVISION FITCHBURG, MA 01420 U.S.A. TEL. 1-800-225-5913 FAX. 978-353-8157</small> | |
| | DESCRIPTION | 7.5" CABLE TIE, STD |
| STOCK NO. | 08387-0 | REV. L |

5 4 3 2 1

AVERY DENNISON MARKETING SPECIFICATION

THE SUBJECT MATTER DISCLOSED HEREIN EMBODIES PROPRIETARY INFORMATION WHICH IS THE CONFIDENTIAL PROPERTY OF THE AVERY DENNISON CO. NONE OF WHICH SHALL BE COPIED, REPRODUCED, DISCLOSED TO OTHERS, PUBLISHED OR USED IN WHOLE OR IN PART FOR ANY PURPOSE OTHER THAN THAT FOR WHICH IT IS BEING MADE AVAILABLE WITHOUT THE EXPRESS ADVANCE WRITTEN PERMISSION OF A DULY AUTHORIZED AGENT OF THE COMPANY. THIS DOCUMENT IS THE PROPERTY OF THE AVERY DENNISON CO. AND IS TO BE RETURNED TO THE COMPANY ON DEMAND.

| HISTORY | | |
|---------|----------|---|
| REV. | DATE | DESCRIPTION |
| K | 01.24.14 | UPDATED TO THE NEW FORMAT; UPDATED DIM 5 FOR EASE OF INSPECTION |
| L | 09.25.14 | ADDED MIN INSTALL TEMP; UL LOGO AND 5000 PER CASE CHG LOOP TENSILE TO NEWTONS |
| M | 08.09.17 | UPDATED DIM 6 TOLERANCE |

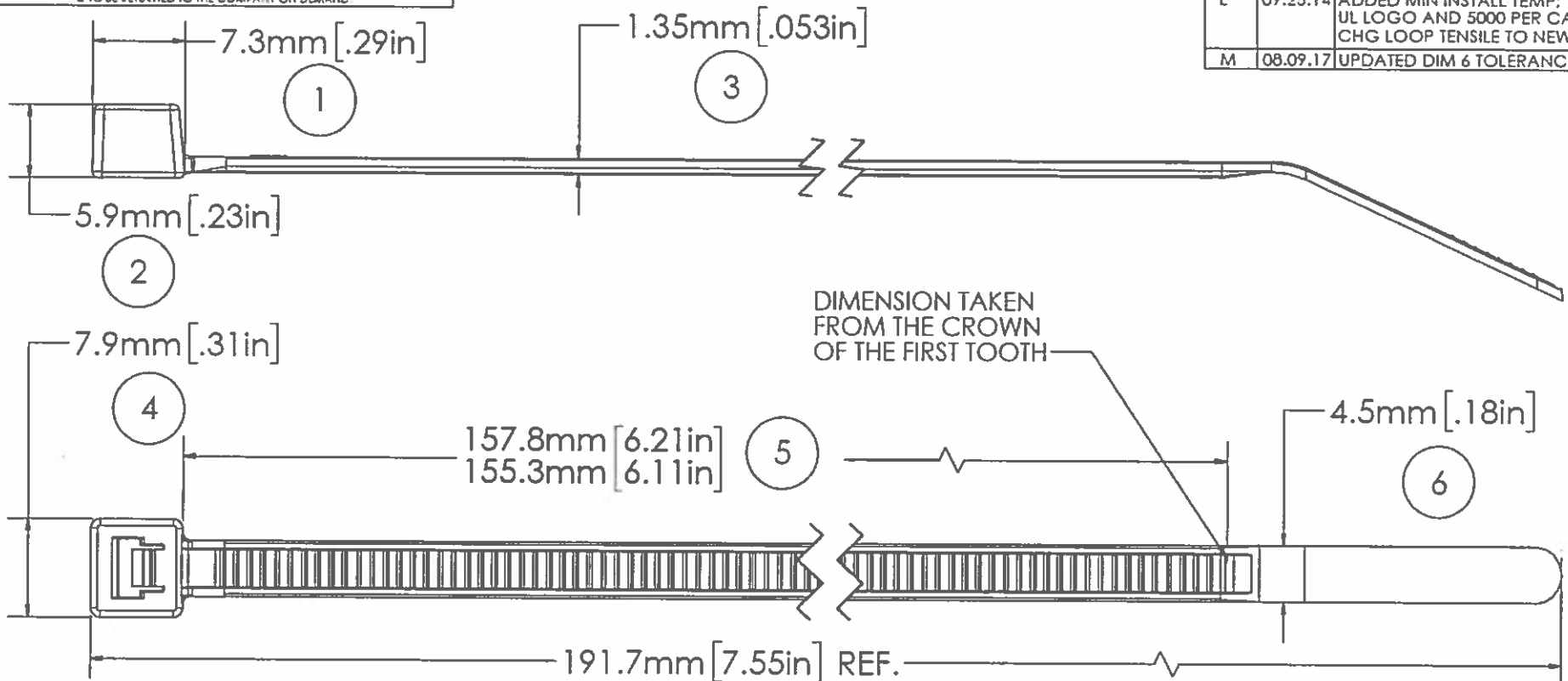

NOTE: THESE CABLE TIES ARE UV RESISTANT AND HAVE A FLAMMABILITY RATING OF V-2



| | |
|-------------------------|---|
| LOOP TENSILE STRENGTH: | 50 LBF / 220N MIN. PER AS-2319D |
| OPERATING TEMP: | -40°F (-40°C) TO 176°F (80°C) |
| MIN. INSTALLATION TEMP: | 32°F (0°C) |
| WEIGHT: | 0.041 OZ./1.20 GRAMS |
| BUNDLE DIAMETER: | 1.59mm - 44.5mm |
| TOOL: | 12001 - HAND INSTALLATION TOOL 12500 - PNUM. INSTALLATION TOOL |
| TOOL TENSION SETTING: | 6 - 8 |
| PACKAGING: | 1000/BAG 5000/CASE (100 PACKS AVAILABLE) |

| | |
|------------|--|
| APPROVALS: | ENG. APPR. <i>[Signature]</i> 08/09/17 |
| | Q.A. APPR. <i>Caitlin Chailancott</i> 5/9/17 |

| | |
|---------------------------|--------------|
| SPECIFIED TOLERANCES ARE: | |
| .XX ± .03 IN. | .X ± .7 MM |
| .XXX ± .01 IN. | .XX ± .25 MM |
| ANGULAR: ± 2° | |

| | |
|----------|---------------------------------|
| MATERIAL | NYLON 6/6, WEATHER RESISTANT |
| COLOR | BLACK |

| | | |
|---|---------------------|------|
| AVERY DENNISON <small>FASTENER DIVISION FITCHBURG, MA 01420 U.S.A. TEL. 1-800-225-5913 FAX 978-253-8157</small> | DESCRIPTION | |
| | 7.5" CABLE TIE, STD | |
| STOCK NO. | 08388-0 | REV. |
| | | M |

AVERY DENNISON MARKETING SPECIFICATION

HISTORY

THE SUBJECT MATTER DISCLOSED HEREIN EMBODIES PROPRIETARY INFORMATION WHICH IS THE CONFIDENTIAL PROPERTY OF THE AVERY DENNISON CO. NONE OF WHICH SHALL BE COPIED, REPRODUCED, DISCLOSED TO OTHERS, PUBLISHED OR USED IN WHOLE OR IN PART, FOR ANY PURPOSE OTHER THAN THAT FOR WHICH IT IS BEING MADE AVAILABLE WITHOUT THE EXPRESS ADVANCE WRITTEN PERMISSION OF A DULY AUTHORIZED AGENT OF THE COMPANY. THIS DOCUMENT IS THE PROPERTY OF THE AVERY DENNISON CO. AND IS TO BE RETURNED TO THE COMPANY ON DEMAND.

| REV. | DATE | DESCRIPTION |
|------|----------|--|
| Q | 10-07-16 | ADDED FLAMMABILITY CALL OUT AND SPECIAL CHAR. NOTE. ; CHG ORIGINAL DIM 5 TO REF. AND CHG DIM 6 TO BE DIM 5 |

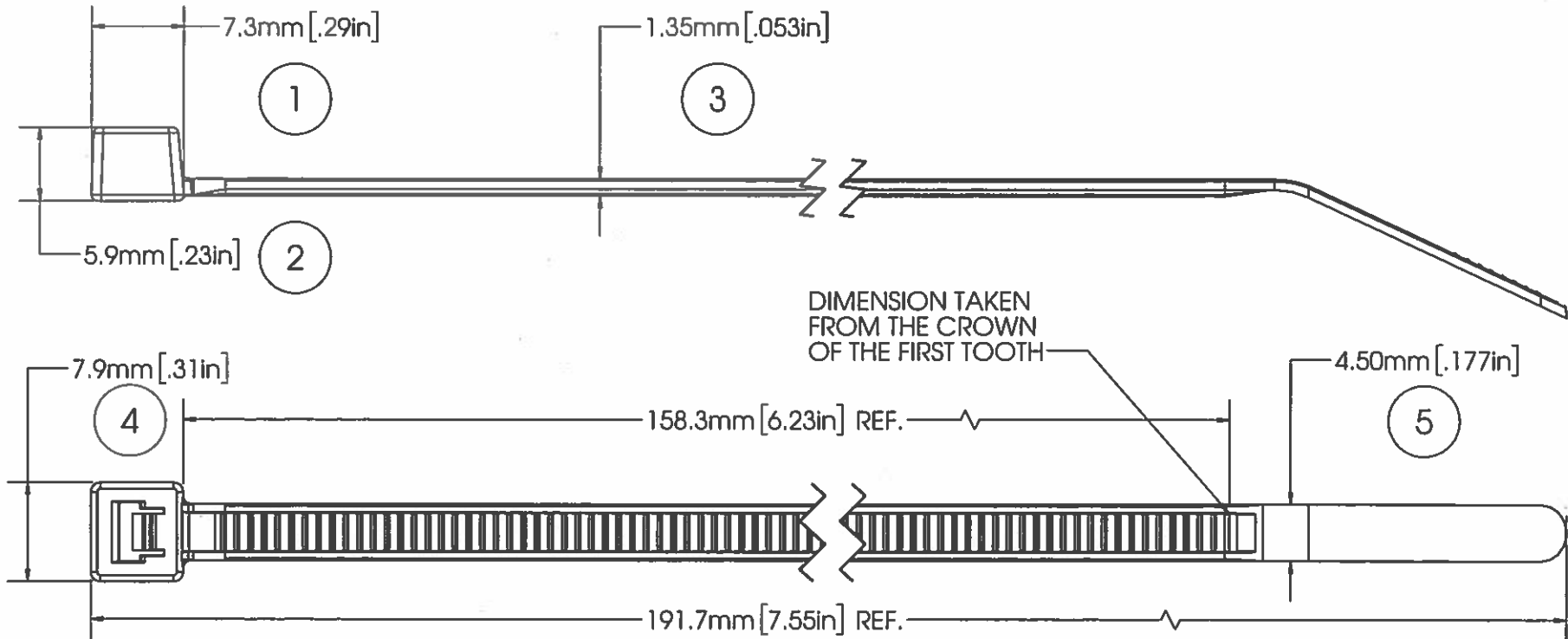

DIMENSION TAKEN FROM THE CROWN OF THE FIRST TOOTH

NOTE:

1. THESE CABLE TIES ARE PLENUM RATED AND HAVE A FLAMMABILITY RATING OF V-2
2. SPECIAL CHARACTERISTICS ARE NOTED BY A TRIANGLE (Δ)



| | | |
|---|---------------------------------|--|
| 6 | Δ FLAMMABILITY RATING: | HB RATED PER FMVSS302 |
| 7 | Δ LOOP TENSILE STRENGTH: | 50 LBF / 220N MIN. PER AS-23190 |
| | OPERATING TEMP.: | -40°F (-40°C) TO 220°F (105°C) |
| | MIN. INSTALLATION TEMP.: | 32°F (0°C) |
| | WEIGHT: | 0.041 OZ./1.20 GRAMS |
| | BUNDLE DIAMETER: | 1.59mm - 44.5mm |
| | TOOL: | 12001 - HAND INSTALLATION TOOL 12500 - PNUEM. INSTALLATION TOOL |
| | TOOL TENSION SETTING: | 6 - 8 |
| | PACKAGING: | 1000/BAG 5000/CASE |

| | |
|------------|--|
| APPROVALS: | ENG. APPR. <i>[Signature]</i> 10/12/16 |
| | Q.A. APPR. <i>[Signature]</i> 10/12/16 |

| SPECIFIED TOLERANCES ARE: | |
|---------------------------|------------------|
| .XX \pm .03 IN. | .X \pm .7 mm |
| .XXX \pm .010 IN. | .XX \pm .25 mm |
| ANGULAR: \pm 2° | |

| | |
|----------|-----------------------------|
| MATERIAL | NYLON 6/6, HEAT STABILIZED, |
| COLOR | BLACK |

| | |
|--|----------------------------|
| AVERY DENNISON <small>FASTENER DIVISION FITCHBURG, MA 01420 U.S.A. TEL. 1-800-225-5913 FAX. 978-353-8157</small> | |
| DESCRIPTION | 7.5" CABLE TIE, STD |
| STOCK NO. | 08402-0 |
| REV. | Q |

5

4

3

2

1

AVERY DENNISON MARKETING SPECIFICATION

THE SUBJECT MATTER DISCLOSED HEREIN EMBODIES PROPRIETARY INFORMATION WHICH IS THE CONFIDENTIAL PROPERTY OF THE AVERY DENNISON CO. NONE OF WHICH SHALL BE COPIED, REPRODUCED, DISCLOSED TO OTHERS, PUBLISHED OR USED IN WHOLE OR IN PART, FOR ANY PURPOSE OTHER THAN THAT FOR WHICH IT IS BEING MADE AVAILABLE WITHOUT THE EXPRESS ADVANCE WRITTEN PERMISSION OF A DULY AUTHORIZED AGENT OF THE COMPANY. THIS DOCUMENT IS THE PROPERTY OF THE AVERY DENNISON CO. AND IS TO BE RETURNED TO THE COMPANY ON DEMAND.

| HISTORY | | |
|---------|----------|---|
| REV. | DATE | DESCRIPTION |
| C | 01.24.14 | UPDATED TO THE NEW FORMAT; UPDATED DIM 5 FOR EASE OF INSPECTION |
| D | 09.25.14 | ADDED MIN INSTALL TEMP; UL LOGO AND 5000 PER CASE CHG LOOP TENSILE TO NEWTONS |

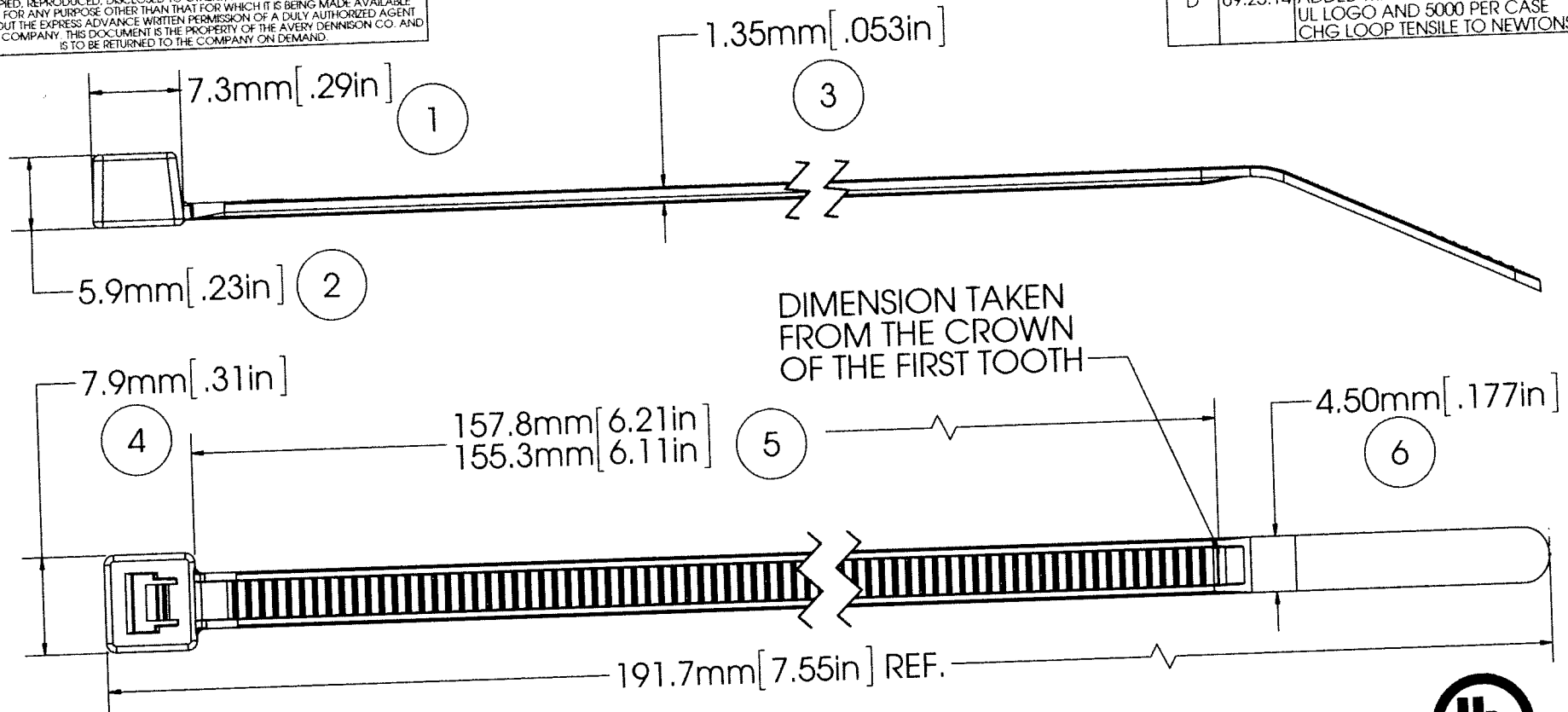

NOTE: THESE CABLE TIES ARE PLENUM RATED AND HAVE A FLAMMABILITY RATING OF V-2

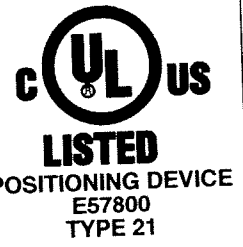

| | | | | | | | |
|-------------------------|---------------------------------|---------------------------|------------|--------------------------------|---------------------------------|---------------------|---------|
| LOOP TENSILE STRENGTH: | 50 LBF / 220N MIN. PER AS-23190 | APPROVALS: | ENG. APPR. | <i>[Signature]</i> 9/25/14 | DESCRIPTION | 7.5" CABLE TIE, STD | |
| OPERATING TEMP: | -40°F (-40°C) TO 185°F (85°C) | | Q.A. APPR. | <i>[Signature]</i> 9/25/14 | | STOCK NO. | 08436-0 |
| MIN. INSTALLATION TEMP: | 32°F (0°C) | SPECIFIED TOLERANCES ARE: | MATERIAL | NYLON 6/6 | COLOR | NATURAL | 1 |
| WEIGHT: | 0.041 OZ./1.20 GRAMS | | | | | | |
| BUNDLE DIAMETER: | 1.59mm - 44.5mm | TOOL: | | 12001 - HAND INSTALLATION TOOL | 12500 - PNUM. INSTALLATION TOOL | 5 | |
| TOOL TENSION SETTING: | 6 - 8 | PACKAGING: | | 100/BAG 5000/CASE | | 3 | |

AVERY DENNISON
FASTENER DIVISION
FITCHBURG, MA 01420 U.S.A.
TEL. 1-800-225-5913
FAX. 978-353-6157

AVERY DENNISON MARKETING SPECIFICATION

HISTORY

THE SUBJECT MATTER DISCLOSED HEREIN EMBODIES PROPRIETARY INFORMATION WHICH IS THE CONFIDENTIAL PROPERTY OF THE AVERY DENNISON CO. NONE OF WHICH SHALL BE COPIED, REPRODUCED, DISCLOSED TO OTHERS, PUBLISHED OR USED IN WHOLE OR IN PART, FOR ANY PURPOSE OTHER THAN THAT FOR WHICH IT IS BEING MADE AVAILABLE WITHOUT THE EXPRESS ADVANCE WRITTEN PERMISSION OF A DULY AUTHORIZED AGENT OF THE COMPANY. THIS DOCUMENT IS THE PROPERTY OF THE AVERY DENNISON CO. AND IS TO BE RETURNED TO THE COMPANY ON DEMAND.

| REV. | DATE | DESCRIPTION |
|------|----------|---|
| C | 01.24.14 | UPDATED TO THE NEW FORMAT; UPDATED DIM 5 FOR EASE OF INSPECTION |
| D | 09.25.14 | ADDED MIN INSTALL TEMP; UL LOGO AND 5000 PER CASE CHG LOOP TENSILE TO NEWTONS |

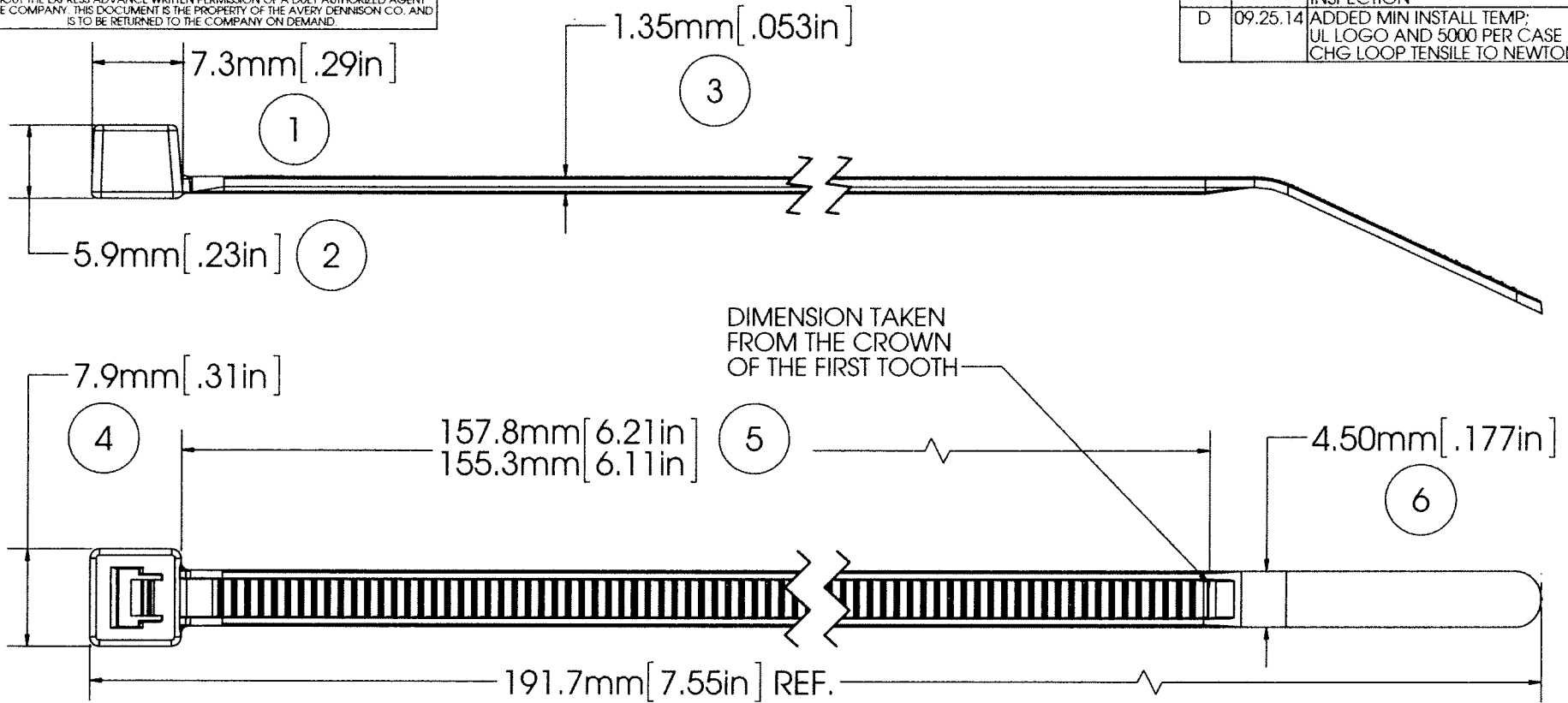

NOTE: THESE CABLE TIES ARE UV RESISTANT AND HAVE A FLAMMABILITY RATING OF V-2



| | | | |
|--|-----------------------------|--|---|
| LOOP TENSILE STRENGTH: 50 LBF / 220N MIN. PER AS-23190 | APPROVALS: | ENG. APPR. <i>[Signature]</i> 9/25/14 | AVERY DENNISON <small>FASTENER DIVISION FITCHBURG, MA 01420 U.S.A. TEL. 1-800-225-5913 FAX. 978-353-8157</small> |
| OPERATING TEMP: -40°F (-40°C) TO 176°F (80°C) | | Q.A. APPR. <i>[Signature]</i> 9/25/14 | |
| MIN. INSTALLATION TEMP: 32°F (0°C) | SPECIFIED TOLERANCES ARE: | MATERIAL NYLON 6/6, WEATHER RESISTANT | DESCRIPTION 7.5" CABLE TIE, STD |
| WEIGHT: 0.041 OZ. / 1.20 GRAMS | | .XX ± .03 IN. .X ± .7 MM | COLOR BLACK |
| BUNDLE DIAMETER: 1.59mm - 44.5mm | .XXX ± .01 IN. .XX ± .25 MM | ANGULAR: ± 2° | REV. D |

5

4

3

2

1